



1 1/16" BORE ACCESSORIES



MOUNTING NUTS

Stud Nut

Part Number	Across Flats	Nut Thickness	Nut (Thread)
N10-18	15/16"	3/8"	5/8-18

Rod Nut

Part Number	Across Flats	Nut Thickness	Nut (Thread)
N05-24	1/2"	3/16"	5/16-24

CB-1795

Clevis Bracket
Material: Steel, bright zinc plated

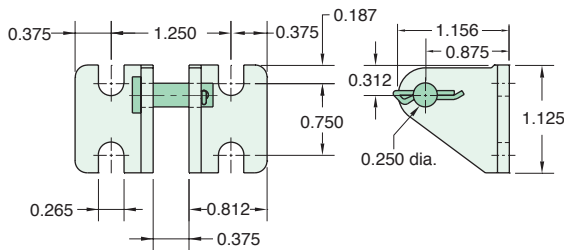

RE-1785

Rod End
Material: Steel, bright zinc plated body

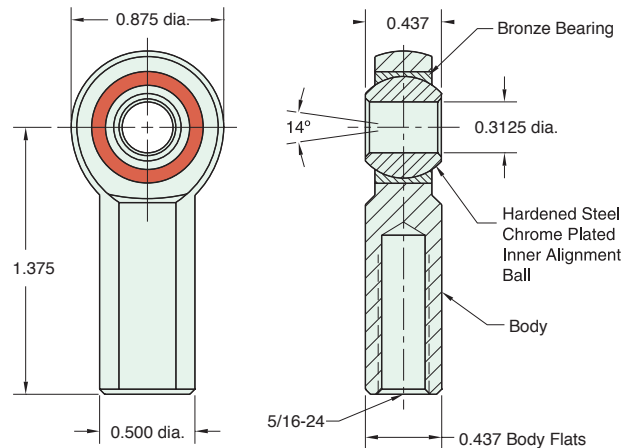

RC-1781

Rod Clevis
Material: Steel, electroless nickel plate

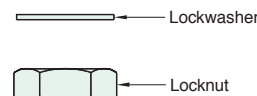
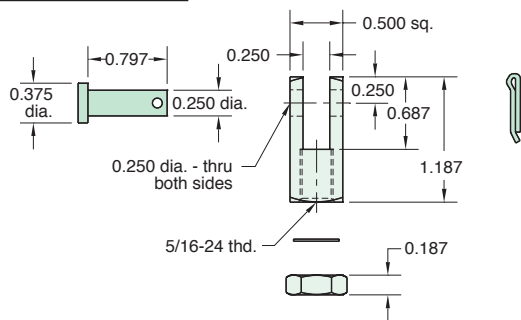

Max. Static Radial Load: 3200 lbs.
Fits Rod Thread Size: 5/16-24

FB-1791

Foot Bracket
Material: Steel, bright zinc plated

